



# UL-FM 200 PSI RESILIENT WEDGE GATE VALVE, SERIES 8000'S, KS-FW 2" – 12"

## Overview

Kennedy Valve Series 8000 KS-FW gate valves are resilient EPDM encapsulated cast iron wedge gate valves that are used in fire protection systems and water service applications. They offer bubble tight, bi-directional, on-off flow control. Series 8000s are compliant with AWWA C509 2" to 12" and UL Listed and FM Approved as KS-FW.

The Series 8000 family utilize triple EPDM o-ring stem seals and o-rings at the bonnet to body connection offering best in class performance and serviceability. The OS&Y utilizes a single o-ring and packing. The two uppermost stem o-rings of the NRS valve as well as OS&Y packing can be replaced while the valve is in service (consult our O&M for details).

Several end conditions are available including: ANSI CL 125 flange, mechanical joint, push on for both C900 PVC and flange by MJ.

Series 8000s are coated with a high-performance heat curable, thermosetting fusion bonded epoxy system. This Kennedy Valve Powder coating system is FDA Title 21 section 175.300 accepted and is AWWA C550 compliant.

All OS&Y valves are manufactured with pre-grooved stems to accommodate tamper switches by others.

Valves can be manufactured to be compliant with Buy American, Buy America, and AIS requirements.

All Kennedy KS-FWs are manufactured and assembled at Kennedy Valve in Elmira, NY.

Manufacturing Standards - ISO 9001, ISO 14001, ISO 45001.



The KVOS2 tamper switch is an available option on 12" and smaller Kennedy OS&Ys.



61/372



## Technical Data

**Available Sizes:** 2" to 12"

**UL-FM Listed and Approved Pressure:** 200psi

### FLANGES

**Stocked:** ANSI B16.1 Flat Face Flange, CL 125, CL 150 Drilling

**Optional:** CL 125 with PN16 Drilling

### GROOVED

**Grooved Ends Stocked:** Standard IPS Grooves per ANSI/AWWA C606

### FASTENERS

**Stocked NRS:** 304 Stainless Steel

**Stocked OS&Y:** Plated Steel

**Optional:** 316 Stainless Steel, OS&Y also available in 304 Stainless Steel

### STEM

#### NON-RISING GATE VALVE

**Stocked:** ASTM B584 High Strength Manganese Bronze

**Optional:** ASTM A276 Type 304ss, Type 316ss or ASTM B763 NDZ Bronze

#### OS&Y GATE VALVE

**Stocked:** ASTM A276 Type 304ss

**Optional:** ASTM A276 Type 316ss, ASTM B98 Silicon Bronze (Everdur), or ASTM B371 (Equal to: Eco Brass™)

### BODY TAPPING

All 12" and down Kennedy KS-FWs can be tapped at up to four locations: A, B, E, F. See figure 3 on page 3 for locations on the valve body. All taps are 3/4" NPT except 4" and down flanged valves are 1/2" NPT taps. Plugs are coated over during the Kennedy Powder Coating process. Plugs can be either silicon bronze or low carbon steel. The plugs are easily removed by utilizing deep well 4-point sockets.

## Components

### NRS WITH POST PLATE

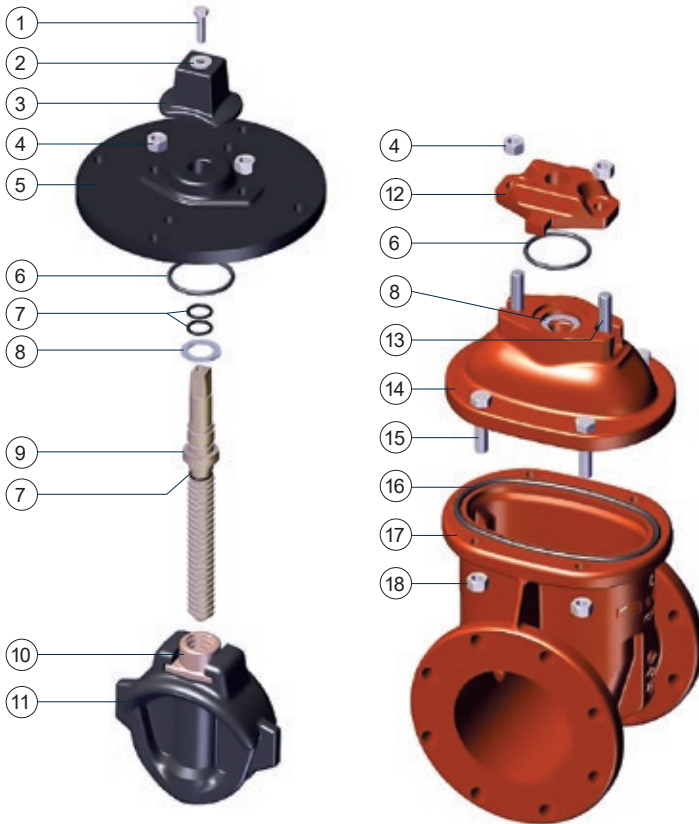

### OS&Y



Figure 1

## Dimensions

No.	NRS	OS&Y	Description	Material
1	•		Op-Nut Bolt	Stainless Steel
2	•		Op-Nut Washer	Stainless Steel
3	•		Op-Nut	Ductile Iron
4	•		Post Plate/Stuffing Box Nut	Stainless Steel
5	•		Post Plate	Cast Iron
6	•		Post Plate/Stuffing Box O-Ring	Rubber
7	•		Stem O-Rings	Rubber
8	•		Thrust Teflon Washer	Plastic
9	•		Stem	Manganese Bronze
10	•		Stem Nut	Bronze
11	•	•	Resilient Wedge	EPDM Encapsulated Ductile Iron
12	•		Stuffing Box	Ductile Iron
13	•		Post Plate/Stuffing Box Plate Bolt	Ductile Iron/Stainless
14	•		Cover	Ductile Iron
15	•	•	Bonnet/Cover/Body Bolt	Plated Steel (OS&Y) Stainless Steel (NRS)
16	•	•	Bonnet/Cover/Body O-Ring	Rubber

No.	NRS	OS&Y	Description	Material
17	•	•	Body	Cast Iron
18	•	•	Bonnet/Cover/Body Nut	Plated Steel (OS&Y) Stainless Steel (NRS)
19		•	Packing Gland	Ductile Iron
20		•	Packing	Garlock Style 18
21		•	Handwheel Nut	Bronze or Zinc Plated Yellow
22	•	•	Handwheel	Cast Iron
23		•	Bonnet/Cover	Ductile Iron
24		•	Yoke Washer	Plastic
25		•	Yoke Nut	Bronze
26		•	Packing Bolt	Plated Steel
27		•	Hex Nut	Brass
28		•	Stem	Pre-Grooved Stainless Steel
29		•	Stem O-Ring	Rubber
30		•	Stem Pin	Stainless Steel
31		•	Stem Nut	Bronze
32		•	Handwheel Yoke Washer	Brass

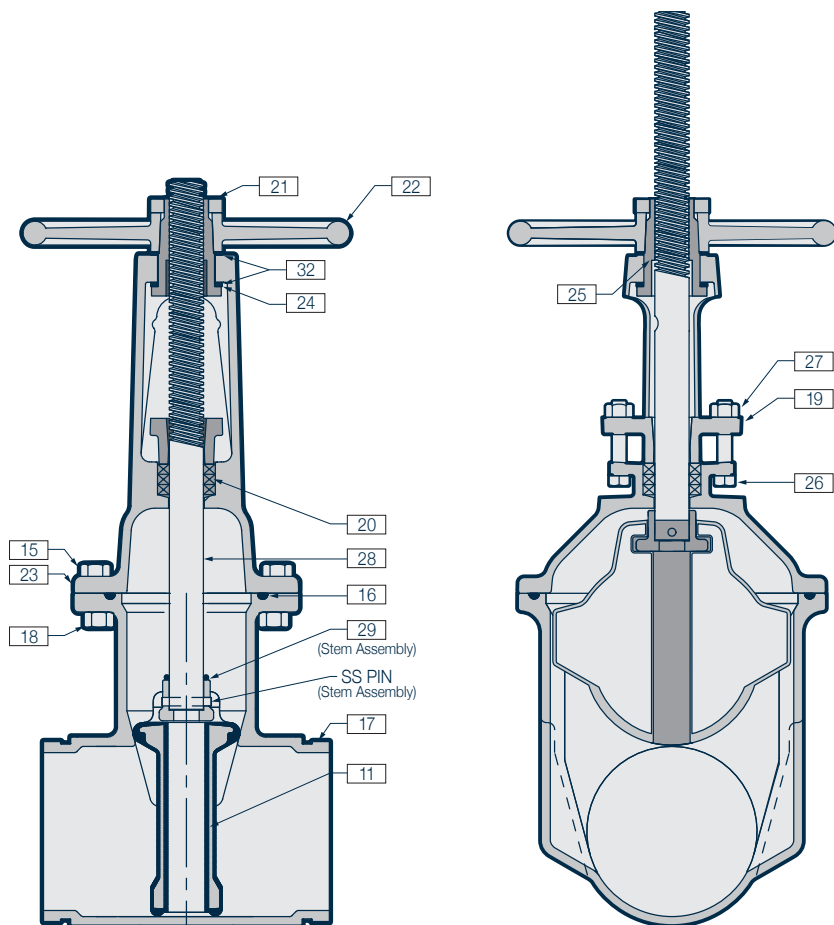

Figure 2

All standard OS&Y valves be provided with smooth stems (no switch activation details)

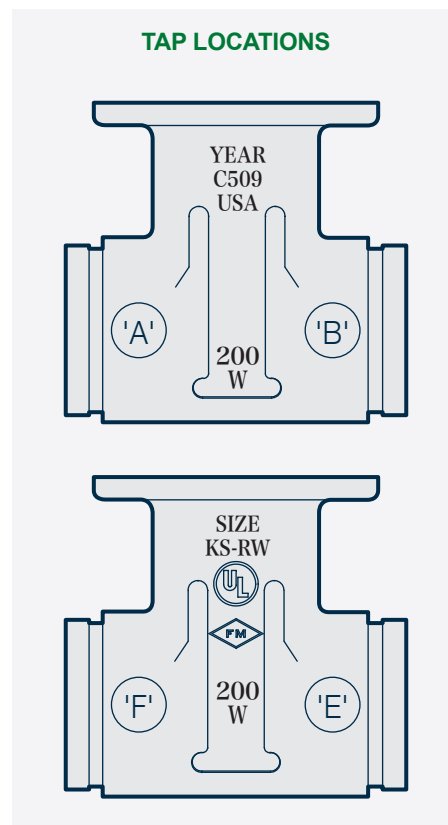

Figure 3

## Bill of Materials

Item	Description	No Req'd	Material
21	Handwheel Nut	1	Bronze ASTM B584 C89833, 87850
22	Handwheel	1	Cast Iron ASTM A-126 Class B
32	Thrust Washer (upper/lower)	1 ea	Bronze ASTM B36 (2"/2.5" Delrin/Celcon)
24	Anti-Friction Bearing	1	Nylatron Sizes 3" - 12"
15/18	Hex Head Bolts / Hex Nuts	varies	Plated Steel
23	Bonnet/Cover	1	Cast Iron
20	Packing	1	Square Braided Non-Asbestos
28	Stem	1	304 Stainless Steel
16	O-Ring	1	Buna-N
29	O-Ring (Stem Assembly)	1	Buna-N
17	Body	1	Cast Iron
11	Resilient Wedge	1	DI ASTM A-536 (65-45-12 or 70-50-5), EPDM Encapsulated Wedge
25	Yoke Nut	1	Bronze ASTM B584 C86700
27	Hex Nuts	2	Brass
19	Gland	1	Ductile Iron ASTM A-536 (65-45-12) or Ductile Iron ASTM A-536 (70-50-5)
26	Square Head Bolts	2	Plated Steel

## Resilient Seated Gate Valves w/KVOS (Factory Installed Tamper)

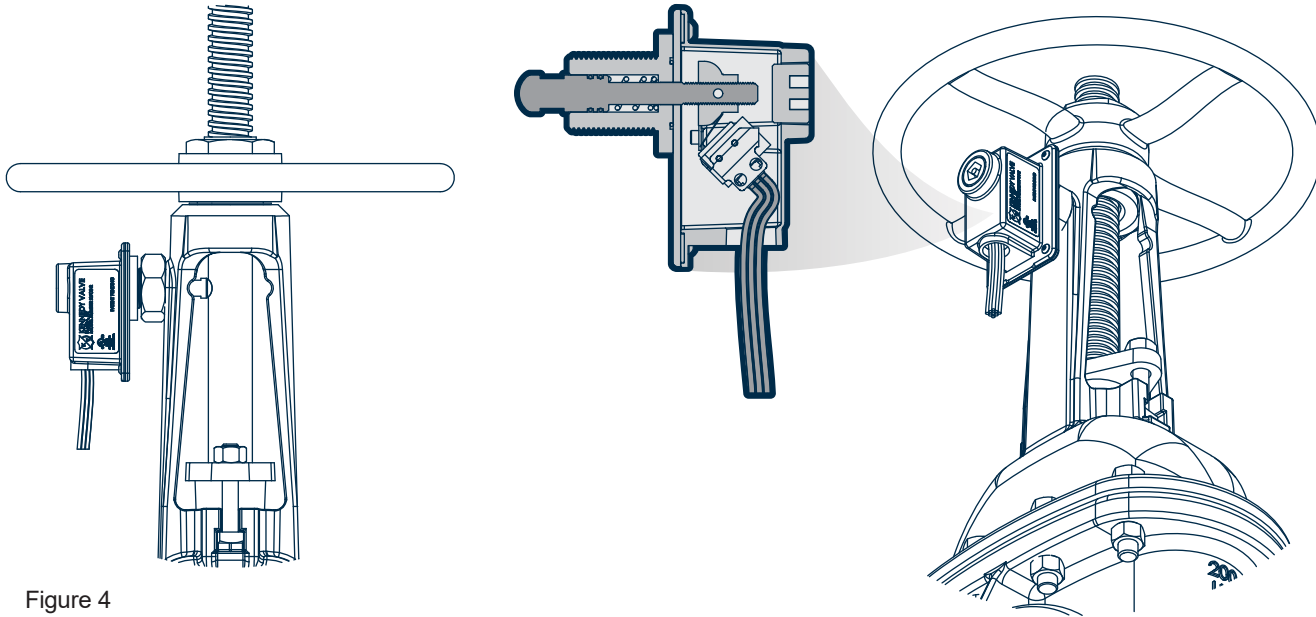

Figure 4



### KVOS-2 For 2"-12" OS&Y Valves

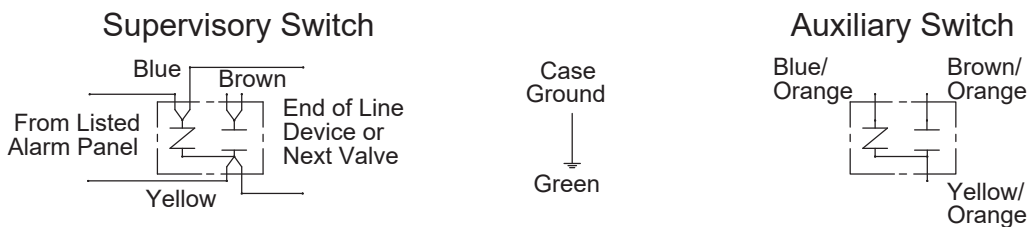

Figure 5

Rated: 120 VAC, 28 VDC, .25 A

**WIRING NOTES:** Connection to power limited circuitry is required. Auxiliary switch is for supplemental use only, and shall not be used for fire alarm signaling applications.

Switches are checked at factory, check continuity with valve fully open, switches activate within two turns from open.

**CAUTION:** PRIOR TO INSTALLATION OF SUPERVISORY SWITCHES IN FIRE PROTECTION SYSTEMS REFER TO THE FOLLOWING STANDARDS:

- NFPA 13: STANDARD FOR THE INSTALLATION OF SPRINKLER SYSTEMS
- NFPA 25: INSPECTION, TESTING, MAINTENANCE OF WATER BASED FIRE PROTECTION SYSTEMS
- NFPA 70: NATIONAL ELECTRICAL CODE
- NFPA 72: NATIONAL FIRE ALARM CODE
- CSA C22.1 NO.1 CANADIAN ELECTRICAL CODE, PART 1, SAFETY STANDARD FOR ELECTRICAL INSTALLATIONS SECTION 32
- CAN/ULC-S524, STANDARD FOR INSTALLATION OF FIRE ALARM SYSTEMS

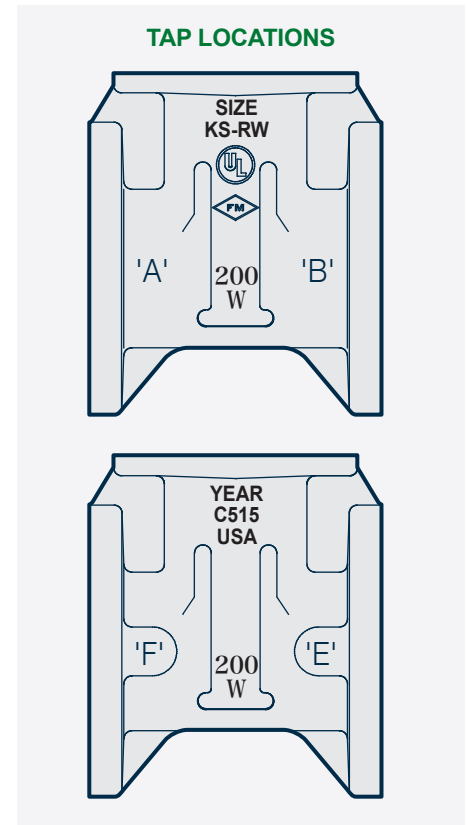
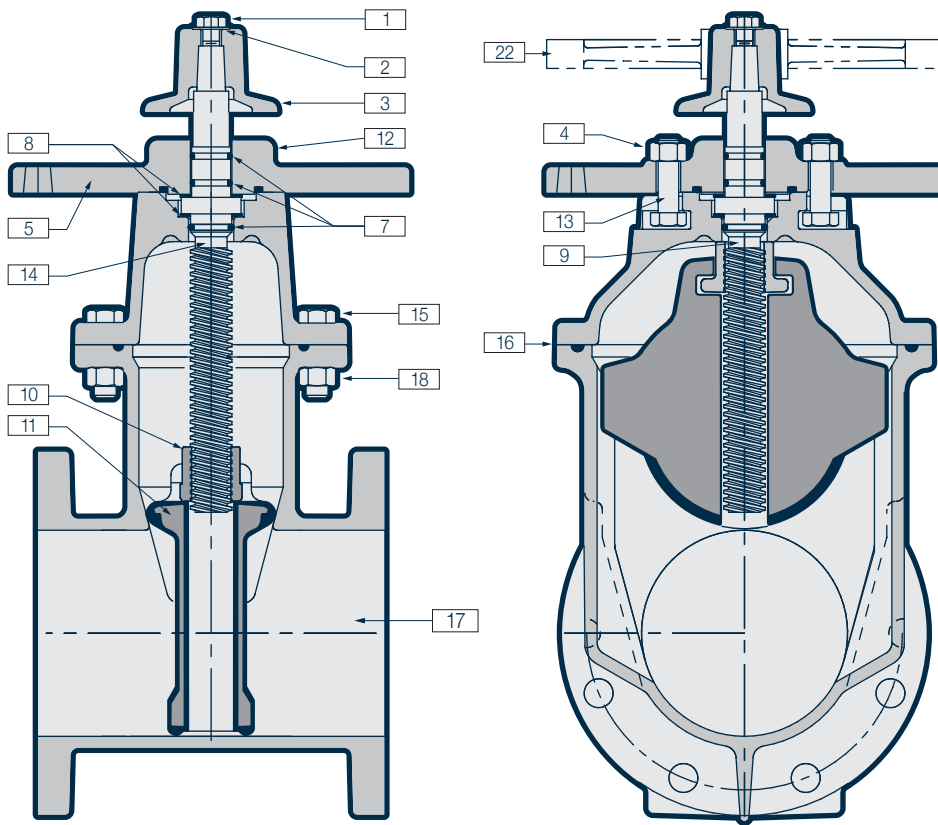

Figure 6

Figure 7

## Bill of Materials

Item	Description	No Req'd	Material
1	Hex Head Bolt	1	Stainless Steel
2	Flat Washer	1	Steel, Plated
3	Operating Nut	1	Cast Iron
12	Stuffing Box	1	Ductile Iron
8	Thrust Washer	1	2" & 2.5" Delrin
		2	3" - 12" Delrin
5	Post Adaptor Plate (Optional)	1	Cast Iron (4 – 3/4" holes on a 10 1/2" diameter B.C.)
14	Bonnet/Cover	1	Cast Iron
10	Stem Nut	1	Bronze
11	EPDM Encapsulated Wedge	1	Ductile Iron
12	Stuffing Box	1	Ductile Iron
7	O-ring (Stem)	3	Buna-N
15	Hex. Head Bolts	Varies	Stainless Steel
18	Hex. Nuts	Varies	Stainless Steel
17	Body	1	Cast Iron
22	Handwheel (Optional)	1	Cast Iron
4	Hex. Nuts	2	Stainless Steel
13	Stuffing Box Bolts	2	Stainless Steel
9	Stem	1	Bronze
16	O-ring (Cover)	1	Buna-N

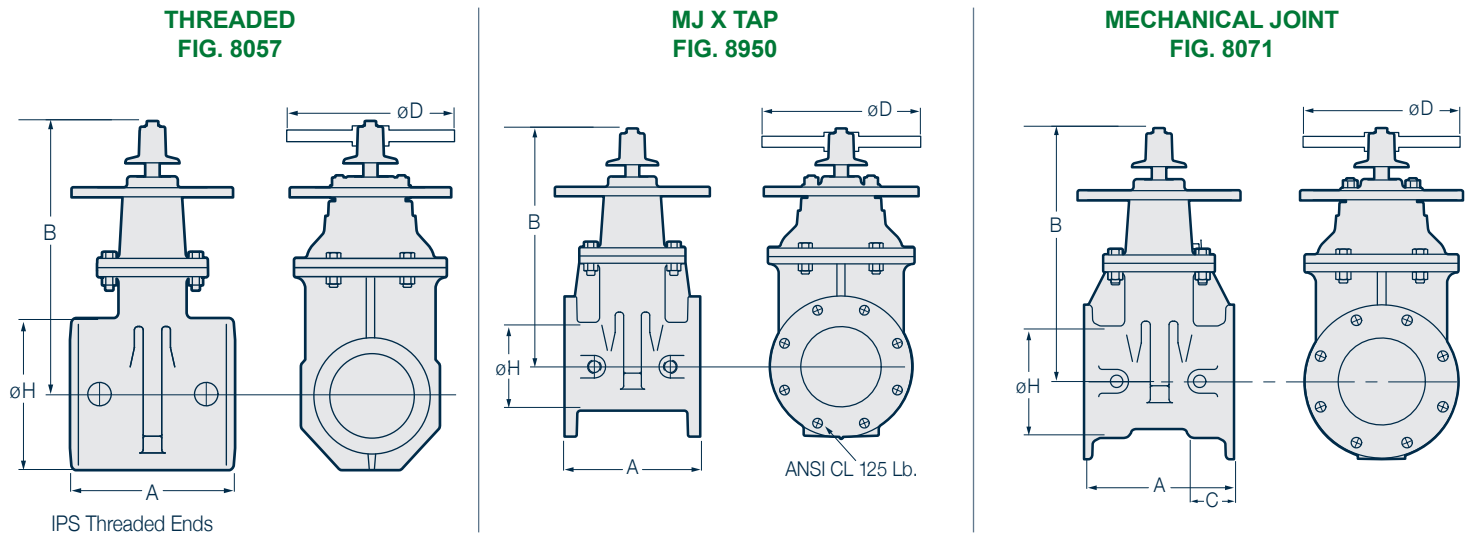

Figure 8  
All NRS Post Plates are 12" diameter unless otherwise noted.

### DIMENSIONS, WEIGHT, AND OPERATIONAL DATA – THREADED – FIG. 8057

Size	Nominal Dimensions			C (depth of socket)	No. of Bolts per Flange and Bolt Size	Weight with Plate	ØD Optional Handwheel Diameter	Turns to Operate	Post Plate Diameter	Cv Full Open
	A	ØH	B							
2½"	7⅞"		12⅞"		NA	NA	7¼"	7¼	12"	500
3"	7⅞"		13⅞"		NA	NA	10"	10	12"	800

### DIMENSIONS, WEIGHT, AND OPERATIONAL DATA – FIG. 8950

Size	Nominal Dimensions			No. of Bolts per Flange and Bolt Size	Weight with plate	ØD Optional Handwheel Diameter	Turns to Operate	Post Plate Diameter	Cv Full Open
	A	ØH	B						
4"	9¼"	4¼"	15¼"	8 - ⅝"	102	10"	14	12"	1500
6"	10½"	6¼"	18⅝"	8 - ¾"	139	12"	20	12"	3600
8"	11½"	8¼"	22⅞"	8 - ¾"	208	14"	26	12"	6700
10"	14⅞"	10¼"	26¾"	12 - ⅞"	340	18"	32	12"	10500
12"	15⅞"	12¼"	30"	12 - ⅞"	446	18"	38	12"	15000

### DIMENSIONS, WEIGHT, AND OPERATIONAL DATA – MJ – FIG. FIG. 8071

Size	Nominal Dimensions			C (depth of socket)	No. of Bolts per Flange and Bolt Size	Weight with Plate	ØD Optional Handwheel Diameter	Turns to Operate	Post Plate Diameter	Cv Full Open
	A	ØH	B							
3"	8½"	3"	13⅞"	2½"	4 - ⅝"	60	10"	10	12"	800
4"	9½"	4¼"	15¼"	2½"	4 - ¾"	90	10"	14	12"	1500
6"	10½"	6¼"	18⅝"	2½"	6 - ¾"	128	12"	20	12"	3600
8"	13⅞"	8¼"	22⅞"	2½"	6 - ¾"	189	14"	26	12"	6700
10"	15½"	10¼"	26¾"	2½"	8 - ¾"	301	18"	32	12"	10500
12"	16"	12¼"	30"	2⅝"	8 - ¾"	384	18"	38	12"	1500

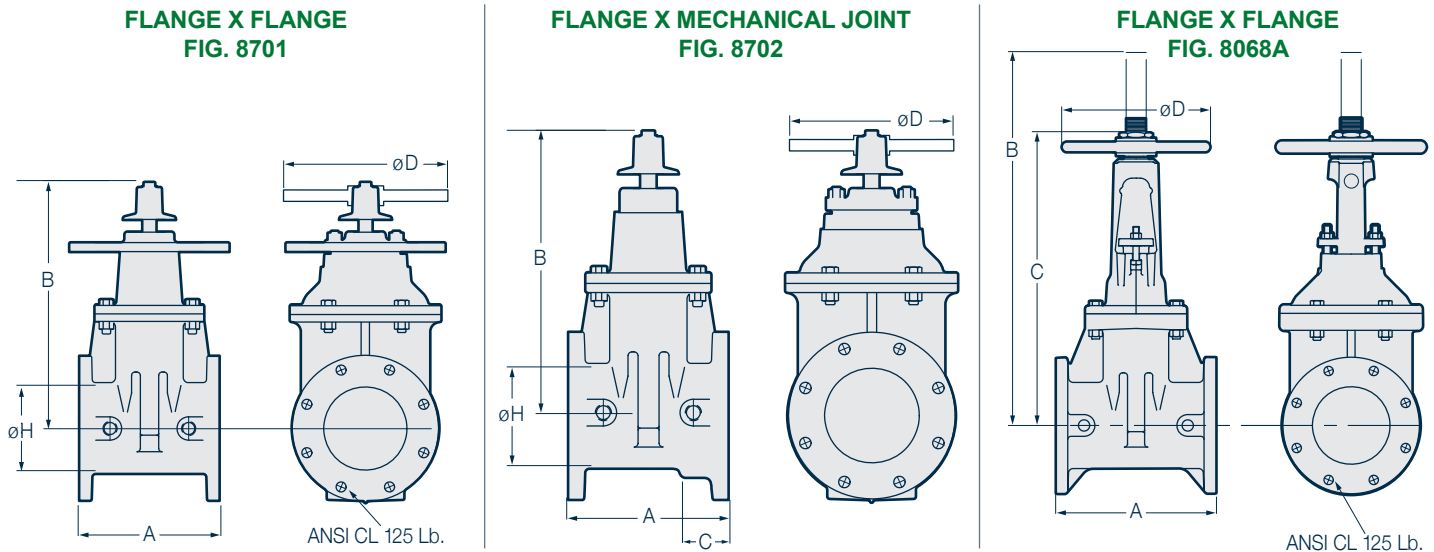

Figure 9  
All Images are shown with Post Plate.

**DIMENSIONS, WEIGHT, AND OPERATIONAL DATA – FLG NRS – FIG. 8071**

Size	Nominal Dimensions			C (depth of socket)	No. of Bolts per Flange and Bolt Size	Weight with Plate	ØD Optional Handwheel Diameter	Turns to Operate	Post Plate Diameter	Cv Full Open
	A	ØH	B							
3"	8"	3"	13⅞"	NA	4 - ⅝"	80	10"	10	12"	800
4"	9"	4¼"	15¼"	NA	8 - ⅝"	102	10"	14	12"	1500
6"	10"	6¼"	18⅝"	NA	8 - ¾"	139	12"	20	12"	3600
8"	11½"	8¼"	22⅞"	NA	8 - ¾"	208	14"	26	12"	6700
10"	13"	10¼"	26¾"	NA	12 - ⅞"	350	18"	32	12"	10500
12"	14"	12¼"	30"	NA	12 - ⅞"	445	18"	38	12"	1500

**DIMENSIONS, WEIGHT, AND OPERATIONAL DATA – FLG X MJ – FIG. 8702**

Size	Nominal Dimensions			C (depth of socket)	No. of Bolts per Flange and Bolt Size	Weight with Plate	ØD Optional Handwheel Diameter	Turns to Operate	Post Plate Diameter	Cv Full Open
	A	ØH	B							
3"	8¼"	3.15"	13⅞"	2½"	4 - ⅝" 4 - ⅝"	NA	10"	10	12"	800
4"	9¼"	4¼"	15¼"	2½"	8 - ⅝" 4 - ¾"	96	10"	14	12"	1500
6"	10½"	6¼"	18⅝"	2½"	8 - ¾" 6 - ¾"	132	12"	20	12"	3600
8"	12⅝ <sup>16</sup> "	8¼"	22⅞"	2½"	8 - ¾" 6 - ¾"	199	14"	26	12"	6700
10"	14¼"	10¼"	26¾"	2½"	12 - ⅞" 8 - ¾"	325	18"	32	12"	10500
12"	15"	12¼"	30"	2⅝"	12 - ⅞" 8 - ¾"	407	18"	38	12"	1500

**DIMENSIONS, WEIGHT, AND OPERATIONAL DATA – FLG OS&Y – FIG. 8068A**

Size	Nominal Dimensions				No. of Bolts per Flange and Bolt Size	Turns to Operate	Weight in Pounds			Cv Full Open
	A	B	C	ØD			G x G	G x F	F x F	
2½"	7½"	16⅜"	13½"	6½"	4 - ⅝"	8	37	40	52	500
3"	8"	18⅞"	15⅞ <sup>16</sup> "	10"	4 - ⅝"	10	48	57	67	800
4"	9"	22¼"	16⅜ <sup>16</sup> "	10"	8 - ⅝"	13½	74	77	92	1500
6"	10½"	30⅞"	23¾"	12"	8 - ¾"	19½	103	115	141	3600
8"	11½"	37¾"	30"	14"	8 - ¾"	25½	139	171	213	6700
10"	13"	45¾"	35⅞ <sup>16</sup> "	18"	12 - ⅞"	31½	294	NA	369	10500
12"	14"	53⅞"	40⅞ <sup>16</sup> "	18"	12 - ⅞"	37¼	326	NA	479	1500