



MCWANE
PLANT & INDUSTRIAL



KENNEDY VALVE

**100% FULL FLOW
ECCENTRIC PLUG VALVE
WITH MECH. JOINT ENDS
AND GEAR FOR BURIED SERVICE
SIZES 18" - 36"**

DRAWING NO.- SUB910280T REV - 10

DRAWN BY - CAW

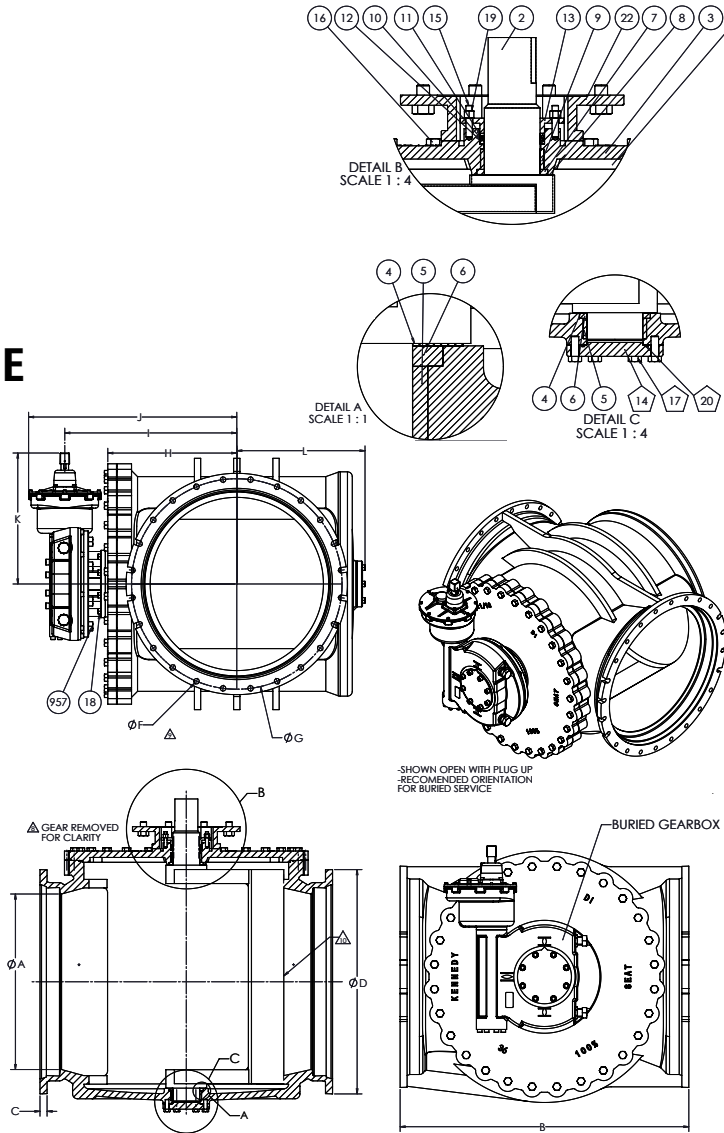

ITEM	PART NAME	ASTM DESIGNATION
1	Body - MJ	ASTM A536 65-45-12 OR 70-50-05
2	Plug	ASTM A536 65-45-12 OR 70-50-05 +NBR
3	Cover	ASTM A536 65-45-12 OR 70-50-05
4	Bottom Thrust Washer	PTFE
5	Botom Bearing	Sintered Alloy SS316
6	GRT Guard Shaft Seal (Lower)	NBR
7	GRT Guard Shaft Seal (Upper)	NBR
8	Upper Thrust Washer	PTFE
9	Upper Bearing Washer	Sintered Alloy SS316
10	V2-Packing-A N6225-55	NBR
11	V2-Top-Packing-A N6225-55	NBR
12	V2-Bottom-Packing-A N6225-55	NBR
13	FP Guard (For Actuator)	ASTM A536 65-45-12 OR 70-50-05
14	Bottom Cover	ASTM A536 65-45-12 OR 70-50-05
15	Cover Studs	Stainless Steel ASTM A276.1316
16	Hexagon Cover Bolts	Stainless Steel ASTM A276.1316
17	Bottom Cover Bolts	Stainless Steel ASTM A276.1316
18	Hexagon Adapter Bolts	Stainless Steel ASTM A276.1316
19	Cover Stud Hex Nut	Stainless Steel ASTM A276.1316
20	O-ring - Bottom Cover	NBR
21	O-ring - Top Cover	NBR
22	FP Adapter - Close	ASTM A536 65-45-12 OR 70-50-05
957	Gear Bolts	Stainless Steel ASTM A276.1316

DIMENSIONS											Weight (lbs.)	Rotork Gear	Gear Ratio	Turns to Open (Approx.)	Water Working Press. PSI	Hydrostatic Test Press. PSI
A	B	C	D	F	G	H	I	J	K	L						
18	29.25	1.00	Ø 24.84	12 x Ø 7/8 THRU	Ø 23-1/4	16.42	21.50	27.6	15.5	18.3	1262	IW6 AWWA-IP68	152:1	38	150 PSI	225 PSI
20	31.00	1.02	Ø 27.08	14 x Ø 7/8 THRU	Ø 25-1/2	17.09	22.25	28.6	15.5	17.4	1537	IW6 AWWA-IP68	228:1	57		
24	42.00	1.02	Ø 31.57	16 x Ø 7/8 THRU	Ø 30	21.06	26.37	35.4	21.6	21.8	3421	IW7 AWWA-IP68	384:1	96		
30	51.00	1.32	Ø 39.12	20 x Ø 1-1/8 THRU	Ø 36-7/8	22.19	30.69	37.2	27.2	22.5	6135	IW9 AWWA-IP68	696:1	174		
36	60.00	1.45	Ø 46.00	24 x Ø 1-1/8 THRU	Ø 43-3/4	26.81	35.75	43.2	27.2	26.6	8515	IW9 AWWA-IP68	928:1	232		

NOTE:

1. Interior and exterior ferrous metal surfaces are epoxy coated.
2. Only 30" and 36" valves have a bottom cover plate (see pentagon ballon items).
3. Mount in orientation shown for buried service.
4. Gearbox for buried service will not have position indicator.
5. Body castings are tri-marked with "Clow", "Kennedy", and "M&H".