



MCWANE
PLANT & INDUSTRIAL



KENNEDY VALVE

100% FULL FLOW ECCENTRIC PLUG VALVE WITH MECH. JOINT ENDS AND DIRECT DRIVE-OP NUT SIZES 3"-8"

DRAWING NO.- SUB910208T REV - 7

DRAWN BY - CAW

SIZE RANGE	WATER WORKING PRESSURE PSI	HYDROSTATIC TEST PSI
3-8	175 PSI	262.5 PSI

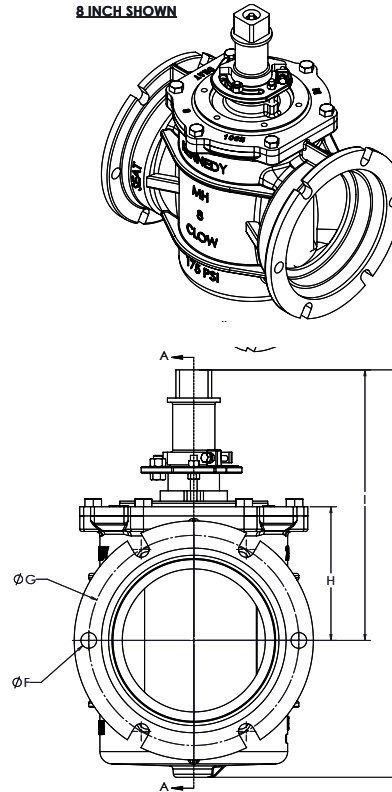
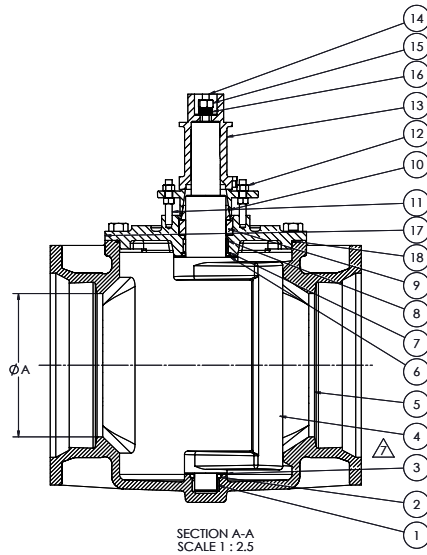
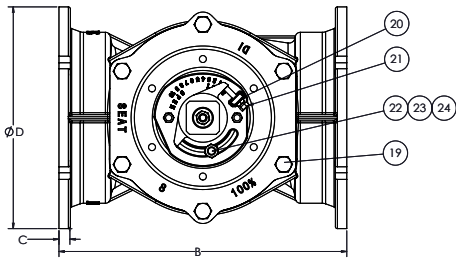

DIMENSIONS									
A	B	C	D	F	G	H	I	J	Weight (lbs.)
3	11.50	.58	Ø 7.62	4 x .75 THRU	Ø 6.19	3.76	9.38	13.24	70 lbs.
4	14.25	.60	Ø 9.06	4 x .88 THRU	Ø 7.50	4.65	10.15	14.86	100 lbs.
6	15.75	.63	Ø 11.06	6 x .88 THRU	Ø 9.50	5.78	12.96	18.75	145 lbs.
8	17.36	.66	Ø 13.39	6 x .88 THRU	Ø 11.75	7.48	15.13	22.79	200 lbs.

ITEM	PART NAME	ASTM DESIGNATION	QTY
1	Lower Sleeve Bearing	Sintered Alloy SS316	1
2	Lower Grit Seal	NBR	1
3	Lower Thrust Washer	PTFE	1
4	Plug	ASTM A536 65-45-12 OR 70-50-05 +NBR	1
5	Body	ASTM A536 65-45-12 OR 70-50-05	1
6	Upper Thrust Washer	PTFE	1
7	Upper Grit Seal	NBR	1
8	Upper Sleeve Bearing	Sintered Alloy SS316	1
9	V-Packing	NBR	1
10	Brake	PPS 40% Glass Filled	1
11	Cover Studs	Stainless Steel ASTM A276.1316	4
12	Cover Stud Hex Nuts	Stainless Steel ASTM A276.1316	2
13	2" Sq. OP-Nut	ASTM A536 65-45-12 OR 70-50-05	1
14	Plug Stem Stud	Stainless Steel ASTM A276.1316	1
15	Hex Locking Nut	Stainless Steel ASTM A276.1316	1
16	Disc Spring Washer	Stainless Steel ASTM A276.1316	5
17	Cover	ASTM A536 65-45-12 OR 70-50-05	1
18	Cover O-ring	NBR	1
19	Cover Bolts	Stainless Steel ASTM A276.1316	4
20	Hex Jam Nut	Stainless Steel ASTM A276.1316	1
21	Followe Sq. Head Set Screw	Stainless Steel ASTM A276.1316	1
22	Socket Head Capscrew	Stainless Steel ASTM A276.1316	1
23	Washer	Stainless Steel ASTM A276.1316	1
24	Hex Jam Nut	Stainless Steel ASTM A276.1316	1

NOTE:

1. Body castings are tri-marked with "Clow", "Kennedy", and "M&H".
2. For service in excess of 25 PSI, use of a gear is recommended.